

MANUAL OF INSTALLATION,
OPERATION AND MAINTENANCE

BOMBAS BEW



ISO 9001

BUREAU VERITAS
Certification



"ISO 9001:2015 Quality
Management System"

 **IMBIL**®

Pumping Solutions

Dear Owner

Congratulations! you have just purchased easy-to-assemble construction equipment, designed and manufactured with the most advanced technology, with excellent performance, providing easy maintenance.

The aim of this manual is to inform the user about the details of the equipment and the proper techniques for Installation, Operation and Maintenance.

IMBIL recommends the installation and handling of this piece of equipment according to the technical specifications and the instructions of this Manual. It is also recommended that this piece of equipment be used according to the service conditions for which it was selected (volumetric flow, total head, speed, voltage, frequency and temperature).

IMBIL is not responsible for faults due to the inobservance of these service orientations. This Manual should be used by the people in charge of installation, operation and maintenance.

 Pumping Solutions	
MODEL:	<input type="text"/>
SERIAL:	<input type="text"/>
TAG:	<input type="text"/>
IMPELLER [Ø]:	<input type="text"/>
SPEED:	<input type="text"/>
DIRECTION:	<input type="text"/>
FLOW [Ø]:	<input type="text"/>
HEAD/ PRESSURE:	<input type="text"/>
DATE:.	<input type="text"/>
<small>IMBIL IND. E MAN DE BOMBAS ITA LTDA - www.imbil.com.br RUA JACOB AUDI, 690 ITAPIRÁ Indústria Brasileira CNPJ.: 51.4826776/0001-26 - FONE(19) 3843-9833</small>	

In case the equipment needs to be verified or when ordering spare parts, please indicate the part code, model, pump series and also the series number found on the identification plate, and engraved in low relief on the suction flange.

NOTE

Right after receiving the WARRANTY DEED of your equipment, please fill in the data and send the stub to IMBIL, so that the information exchange between IMBIL and the client can be facilitated.

Topic	
SUBJECT	PAGE
Inspection upon Receipt	3
Transport	3
Storage	4
Localization	4
Foundation	5
Leveling and Seating of the Base	5
Alignment of the Coupling	6
General Recommendations for the Pipings	6 e 7
Blind Stage	8
Impeller Diameter Lowering	8
Steps for Start-up	9
Immediate Steps after Start-up	9
Steps for Stoppage of Pump	10
Maintenance of Bearing House	10
Maintenance of Packing	10 e 11
Areas of Wear	12
Equipment Periodic Inspection	12
Details for Disassembling and Assembling	13
Operation Anomalies and Likely Causes	14, 15 e 16
Recommended Spare Parts	17

INSPECTION UPON RECEIPT

Inspect the equipment as soon as it is received, check it against the invoice, and notify shipper immediately of any missing or damaged parts.

TRANSPORT

- 1 – Transport of the connected assembly or of separate parts of the equipment must be done carefully and in accordance with security standards.
- 2 – Before the motor and the pump are coupled, they must be transported by the hoisting eye or hoisted, as shown in the figure below.

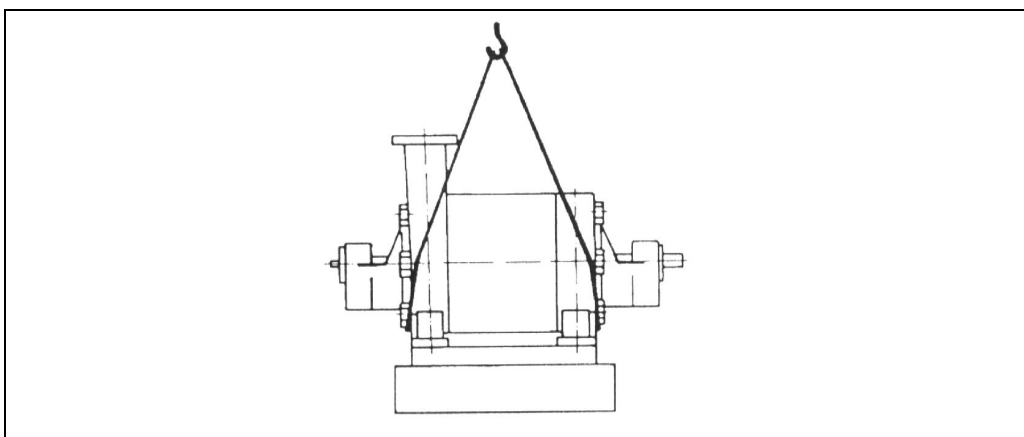

- 3 – The motor-pump assembly must be transported in accordance with the figure below.

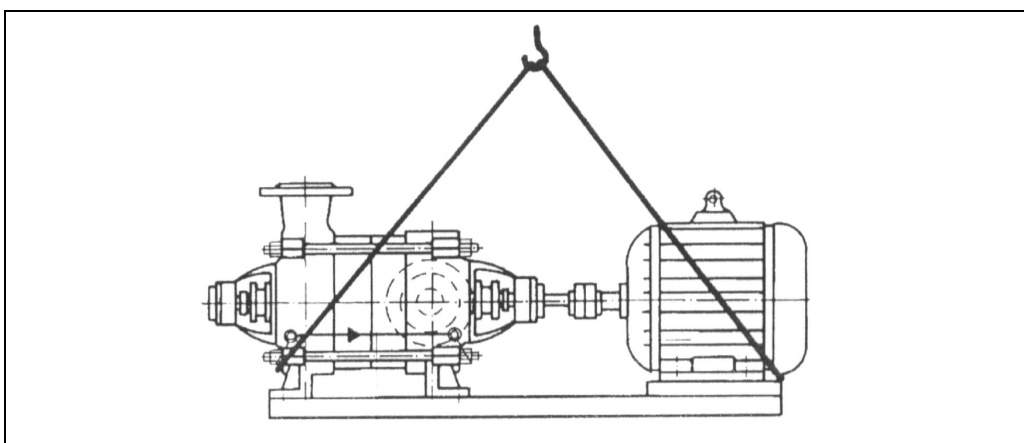

STORAGE

- 1 – When it is necessary to store a pump until it can be installed, do not remove the protection flanges from the nozzles or any other protection sent by IMBIL.
- 2 – The bearing houses are lubricated in the factory. This lubrication protects against oxidation for a short period of time.
 - For pumps stored for periods greater than 30 days, special precautions will be required.
 - Remove the packings and the mechanical seals to avoid corrosion of the sleeves, or avoid the damage of the sealing components such as O'rings, joints and seats.
 - Every 30 days sprinkle DW 301 rustilo oil on the pump. Greasy bearings do not need to receive new load.
 - Rotate the shaft weekly by hand so that all moving parts are lubricated.

NOTE: Before installation of the pump, clean the shaft end, sleeve and flange protections with a proper solvent and follow the instructions of this manual.

LOCALIZATION

Choose the site for installation so that:

- 1 – It is easily accessible for inspection and maintenance.
- 2 – It is above flood level.
- 3 – The pipings are simple and direct so that the NPSH* is sufficient, avoiding cavitation.
- 4 – There is sufficient space to remove the motor.
- 5 – The foundation is stable, causing it not to move horizontally or vertically, leaving the pump supported by the pipings.
- 6 – The identification plates on the pump and on the motor are visible.
- 7 – There is sufficient air circulation around the motor to ensure perfect cooling.

$$*NPSHr = 10 - H_s + V^2/2g + 0.5$$

Where:

NPSHr = required suction height (m)

Hs = suction height (m)

V = suction velocity (m/s)

g = acceleration of gravity (m/s²)

FOUNDATION

The pump should be preferably installed in a horizontal position. Use a single base for the pump and the motor, on a permanent concrete or structural steel foundation with enough

mass to absorb normal vibrations, preventing any distortions in the assembly or any impairment of its alignment.

LEVELING AND SEATING OF THE BASE

- 1 – Place the anchor bolts in the holes in the foundation block under the base holes. Between the anchor bolts and the base, place metallic wedges for the leveling.
- 2 – Insert specific cement mortar around the anchor bolts and under the base through the existing openings, filling all spaces for solid attachment and a vibration-free operation.
- 3 – Tighten the nuts of the anchor bolts after the mortar has cured, checking the transverse and longitudinal leveling, assuring a precision level (0.1 mm/m). If the assembly is not leveled, add thin plates between the base and the wedge for its correction.

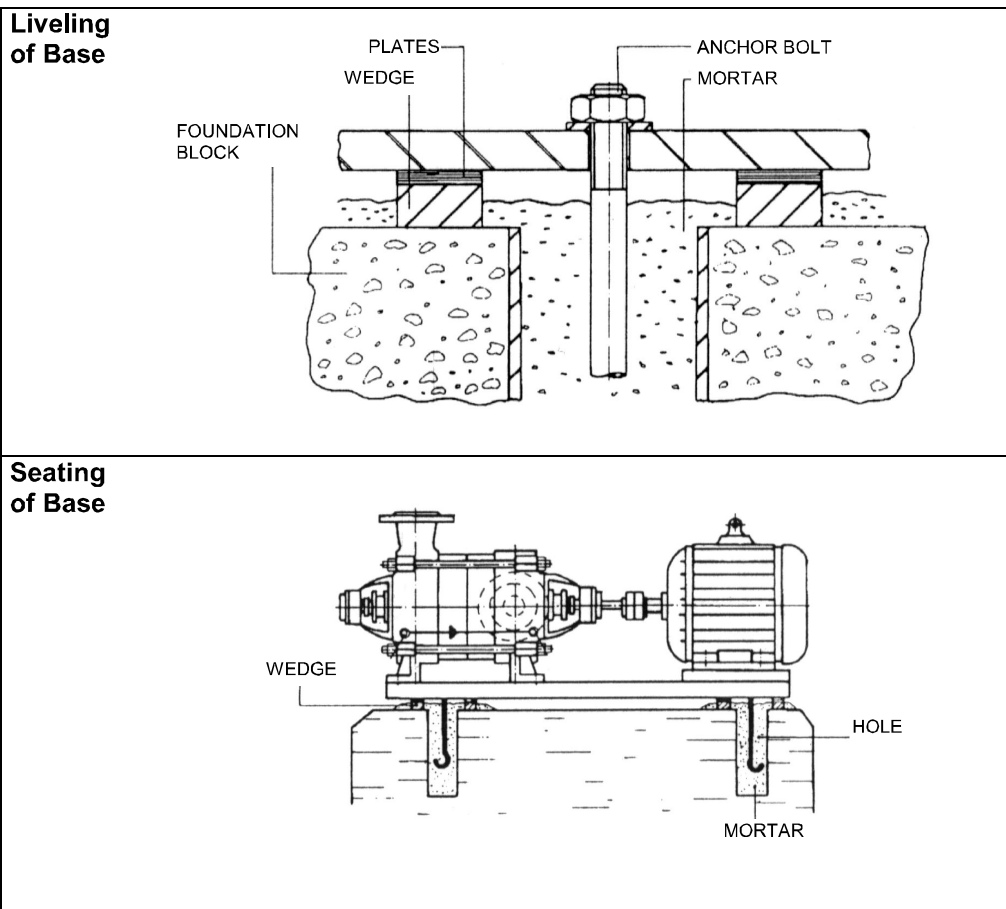

ALIGNMENT OF COUPLING

- 1 – Perform alignment with the suction and discharge pipings already connected.
- 2 – The coupling installation must be performed hot (oven or oil bath at 100C – 212 F). When performing the coupling assembling operation, do not hit it.
- 3 – With the aid of a dial feeler gauge or, if unavailable, a metal straight edge and a blade feeler gauge, control any radial and axial misalignment in order to avoid abnormal vibrations which could interfere with the durability of the equipment.

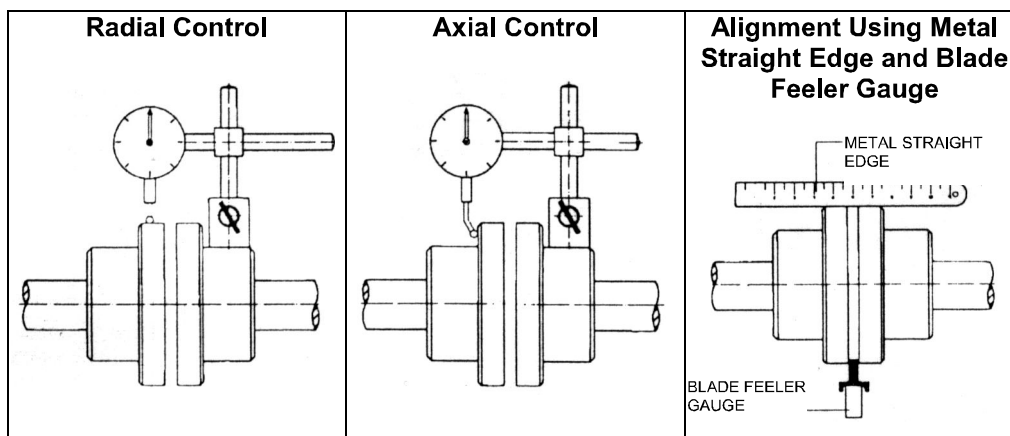

- 4 – When the operation is performed by belts, the pump and the drive shafts must be parallel, the pulleys must be aligned with each other and the belts must be stretched correctly.
- 5 – Radial and axial alignments must remain within a tolerance of 0.15 mm, and the clearance between the motor and the pump shaft ends must comply with coupling manufacturer's specifications.
- 6 – For greater safety of operation, a Coupling Protector or Operation Protector must be installed (for example, belt guard), as required by Law 65/4, regulation MTb 3214 (NR 12 item 12.3).

GENERAL RECOMMENDATIONS FOR THE PIPINGS

For Suction and Discharge Piping

- 1 – The piping must be connected to the pump flange only after the mortar securing the base has cured.
- 2 – In order to avoid head losses, the piping, whenever possible, must be short and straight, and the curves, when necessary, must be long-radius.
- 3 – The pump must not serve as a support for the piping. The piping flanges must be connected to those of the pump totally free of tension, and without transmitting any forces to the volute case, in order to avoid misalignment and its consequences.

- 4 – Expansion joints must be provided when the pumped liquid will be subject to large variations in temperature.

For Suction Piping Only

- 1 – The horizontal industrial application of the suction piping, if positive, must be installed with a slight acclivity in the pump-suction tank direction, and if negative with a slight decline in the same direction, avoiding air pockets. See figures 8 and 9.
- 2 – The nominal diameter of the pump suction flange does not determine the nominal diameter of the suction piping. The speed of the flow of the liquid must be established between 1 and 2 m/s. When it is necessary to use a reduction, it must be eccentric and assembled with the cone down avoiding air pockets. See figures 8 and 9.
- 3 – Foot valve, when applicable, generally receives a filter in order to prevent foreign particles from reaching the pump.
Ensure that the area for passage of the valve is 1.5 times larger than the area of the piping, and that the area of free passage of the filter is 3 to 4 times larger than the area of the piping.
- 4 – In installations with positive suction, installation of a valve to block the passage of the liquid is recommended. Make sure that during pump operation the valve remains completely open.
- 5 – It is advisable to avoid assembling more than one pump to a single suction piping, especially when the absolute pressure in the piping is lower than the manometric head with the pump in operation.
- 6 – A valve must be provided for each pump in installations where various pumps are suctioning from the same tank, and the tank and suction piping must be connected with changes in direction of less than 45 degrees.

For Discharge Piping Only

- 1 – It is necessary to install a valve for regulation of the volumetric flow and pumping pressure immediately after the discharge flange of the pump.
- 2 – It is advisable to install a check valve between the pump outlet and the valve when the length of the discharge piping is relatively long and the total elevation of the pump is greater than 15 meters.
- 3 – When the diameter of the piping is different from the diameter of the discharge flange, the connection must be made by means of concentric reduction.
- 4 – Provide air valves where it is necessary to blow down the air.
- 5 – For pumps installed in parallel, each pump must have its own check valve in order to prevent return or overloading of the foot valve when one of the pumps is disconnected.

6 – Protect the pump against operation below the Minimum Volumetric Flow using a Calibrated Hole, which maintains the by-pass permanent to the suction reservoir or Minimum Volumetric Flow Valve that opens an alternative pathway whenever the Volumetric Flow is reduced below a minimum value ($0.2 \times Q$). Size the velocity in this 4.5 m/s extension.

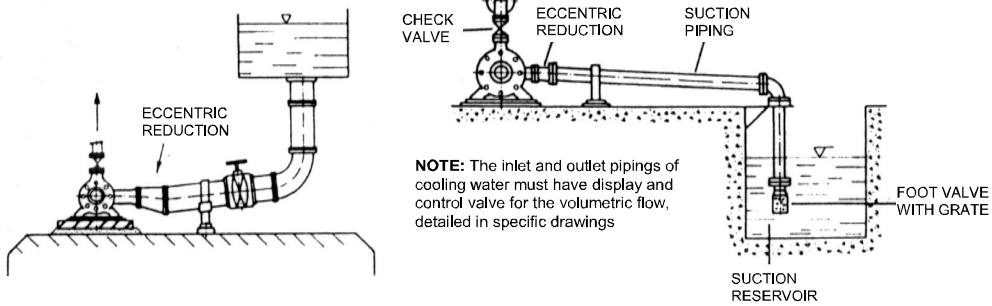

BLIND STAGE

In case the pump must operate during a period in conditions different from the original size, one or more impellers and diffusers are temporarily eliminated, replacing them with sleeves according to the following table and figure:

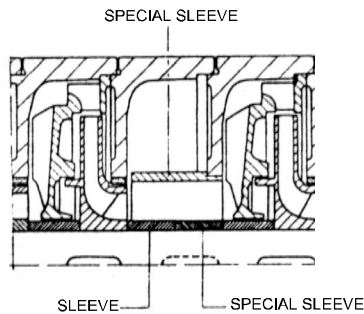

Nº of Pump stages	NUMBER OF BLIND STAGES								
	1	2	3	4	5	6	7	8	
1	S	N	N	N	N	N	N	N	N
2	N	S	S	S	S	S	S	S	S
3		N	S	N	S	N	S	N	S
4			N	S	N	S	N	S	N
5				N	S	N	S	N	S
6					N	S	N	S	N
7						N	S	N	S
8							N	S	N
9								N	S
10									N
11									N
12									N
13									N
14									N
15									N
16									N
17									N

Where: S = Blind Stage, N = Normal Stage
 Note: Follow the sequence above from the suction side, always finalizing with a normal stage

IMPELLER DIAMETER LOWERING

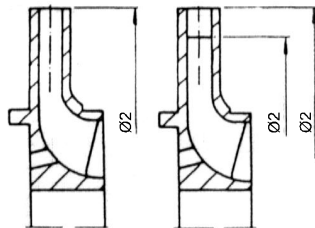

To perform, check the figure on your left, regarding the machining of the vanes, keeping the walls lateral.

STEPS FOR START-UP

- 1 – Check if the assembly is aligned and well connected to the base, if the suction and discharge flanges are well connected to the piping, and then, put into operation the auxiliary connections.
- 2 – Remove possible dirt and humidity from the bearing houses and fill them with the quantity and quality of oil specified in the “Bearing House Maintenance” item.
- 3 – Make the electrical connection in a manner that guarantees that the motor protection system works properly.
- 4 – Check the rotation direction of the drive with the pump disconnected.
- 5 – Prime (fill) the pump and its suction piping, removing any air present. Rotate the pump shaft by hand in order to guarantee good priming. Priming may also be performed by vacuum.
- 6 – When there is a valve of the suction piping, it must be kept completely open, and it must never be used to regulate the volumetric flow of the pump, avoiding the possibility of cavitation, but must be used only for insulation for maintenance.
- 7 – The valve in the discharge piping must be closed at the beginning of operation, in order not to overload the motor and the electrical network during start-up.
- 8 – -When the drive is already operating with nominal rotation, open the discharge piping valve slowly in order to regulate the pump capacity.
- 9 – In long and empty discharge pipings, when the pump is started it is essential to close the discharge valve at the beginning of the operation.

IMMEDIATE STEPS AFTER START-UP

- 1 – Make sure that the assembly operates without abnormal noises or vibrations.
- 2 – Control the tension value of the network and the amperage of the electric motor.
- 3 – Control the temperature of the bearing houses. It must not exceed 45 °C above room temperature.
- 4 – Adjust packing by tightening the nuts on the stuffing box packing gland uniformly, allowing for dripping (following the minimum escape values of 10 cm³/minute and maximum 20 cm³/minute). Lubrication of the packing is performed by the pumped liquid itself.
- 5 – Check the suction pressure, discharge pressure and volumetric flow.
- 6 – Check if the cooling water temperature differential is not over 10 °C, and if its device, which ensure the minimum volumetric flow, is operating properly.

NOTE: Control the above items every 30 minutes in the first two hours, then hourly during the next 10 hours, and weekly after that.

STEPS FOR STOPPAGE OF PUMP

- 1 – Close the valve in the discharge piping.
- 2 – Close the suction valve when maintenance is necessary.
- 3 – Disconnect the drive, observe the gradual stoppage of the equipment.
- 4 – Close any auxiliary piping.

MAINTENANCE OF THE BEARING HOUSE

- The pump has the bearing houses already lubricated in the factory, with lithium-based grease, with dripping point less than 180C (356 F).
- The bearing house must be lubricated every 3 months, preventing it from deterioration and oxidation. The bearing house must be washed every 2 years.

Table of Recommended Types of Grease

Manufacturer	Up to 3000 rpm
CASTROL	LM 2
ATLANTIC	LITHOLINE 2
ESSO	BEACON 2
IPIRANGA	ISAFLEX 2
MOBIL	MOBIL GREASE 77
PETROBRÁS	LUBRAX INDL GM A 2
SHELL	ALVANIA R 2
TEXACO	MARFAK MP 2

MAINTENANCE OF THE PACKING

If the stuffing box packing gland has already been tightened more than 8 mm and there is still excessive leakage, change the packings as follows:

- 1 – Loosen the nuts of the stuffing box packing glands and then remove the stuffing box packing gland.
- 2 – Carefully remove the packings using a flexible rod, and clean the packing housing well, removing any residue.
- 3 – Check if the surface of the shaft sleeve is smooth, with no grooves or marks, which could harm the packing. If the shaft sleeve is marked, it may undergo re-machining in its external diameter to a maximum of 1 mm, or it must be replaced.

- 4 – The packings are usually provided as continuous strips, which must be cut into rings with oblique ends of the proper size for the diameter of the shaft sleeve and assembled according to the instructions below.

Oblique Cut of the Packing

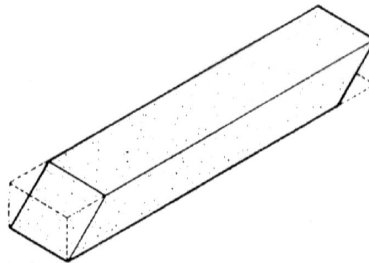

- 5 – To cut the packing rings, it is recommended the use of a simple device as shown in the figure below:

Device to cut packing rings

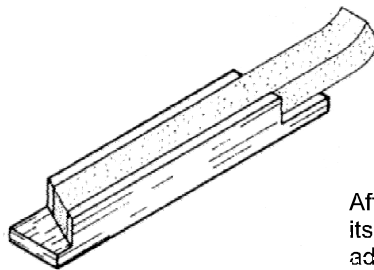

After cutting the first ring, make sure its size is correct, for a perfect adjustment in the packing housing.

- 6 – Spread a thin layer of grease on the internal and external diameters of the packing rings and assemble one at a time in the following order:

- One packing ring.
- One lantern ring.
- The other packing rings.

Displace the splice of the second ring approximately 120 degrees from the position of the first ring, and proceed consecutively in this manner until the last packing ring matches the figure below:

Position of rings displaced 120°

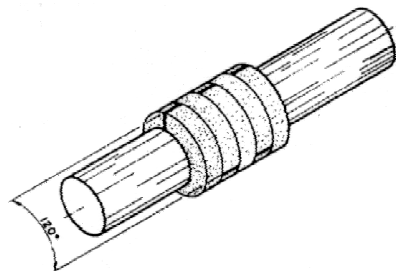

- 7 – Check if the shaft can be rotated after the assembling of each ring, place the stuffing box packing gland compressing the last ring; tighten the nuts by hand and rotate the shaft to confirm that it does not rest on the stuffing box packing gland.

AREAS OF WEAR

1 – When the pump presents volumetric flow or insufficient pressure due to ring wear, the rings must be replaced. IMBIL and its Authorized Resellers can supply parts with the proper tolerances and maintenance services.

2 – Replacement should be undertaken when the clearance between impeller and cover rings or volute case shows wear three times greater than the original clearance.

EQUIPMENT PERIODIC INSPECTION

WHAT ?	WHEN ?			
	WEEKLY	MONTHLY	SEMIANNUALLY	YEARLY
Abnormal vibrations and noises	■			
Leaking of the packings	■			
Point of Operation of the Pump	■			
Suction pressure	■			
Oil level	■			
Chain worn by the motor and tension value in the network	■			
Bearing house temperature		■		
Oil change interval (See Bearing House Maintenance item)		■		
Alignment of Motor- Pump assembly			■	
Fixation bolts of the Pump, Base and Drive			■	
Replacement of packing, if necessary			■	
Lubrication of coupling, when applicable			■	
Disassemble the Pump for maintenance and inspect thoroughly: bearing houses and bearings, retainers, O'rings, joints, impellers, inside of volute case, thickness of walls, areas of wear, coupling, etc.				■
Check the minimum volumetric flow device			■	

* Annual inspection may be Biannual in installations operating in good conditions and when the pumped liquid is not damaging the Pump materials.

DETAILS FOR DISASSEMBLING AND ASSEMBLING

- 1 – Disconnect the drive following the security standards regarding the electric parts.
- 2 – In boilers or thermal oil pumps, it is necessary to wait for the complete cooling.
- 3 – Start the disassembling from the side of the discharge volute case (Ball Bearing), using proper tools (Two-claw extractor) and common tools (Open End Wrench / Wrench, Screwdriver, Ring Pliers etc), remove the parts and put them in order. It facilitates the re-assembling process. Mark the stage pieces / diffusers / impellers / sleeves etc.
- 4 – Analyze the removed parts, one by one, regarding the excessive wear and other faults that demand part replacement, such as:
 - Warped Shaft larger than 0.08mm per meter.
 - Stage pieces out of parallelism greater than 0.1mm.
 - Bearings with excessive clearance, excessive oxidation and overheated.
 - Sleeves/wear rings worn above accepted.
- 5 – Clean the parts, remove the fins and lubricate the seals using molybdenum bisulfate), to perform the re-assembling from the suction side, following the previously marked sequence.
- 6 – When placing and tightening the tie bars, use the crossed sequence and torquemeter key for tightening, following the values below:
 - BEW 32 = 8 Kgf.m
 - BEW 125 = 30 Kgf.m
 - BEW 80 = 20 Kgf.m
 - BEW 150 = 35 Kgf.m
 - BEW 100 = 25 Kgf.m
- 7 – Adjust the axial clearance including adjustment washers, so that the sleeves and impellers do not have some movements between the back-up rings.
- 8 – Adjust the impeller + shaft assembly inside the pump, by moving it until it rests internally on the diffusers on both sides. Write down the distance value up to the bearing face, which must be the same as the thickness of the distancing ring. Assemble the bearing with the conical sleeve beside the coupling. Before placing the packing, make sure the pump rotates freely.

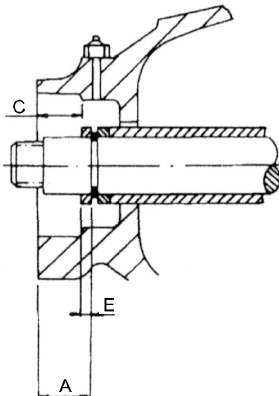

RING THICKNESS = "E" = Average A – C
 WHERE: Average = $A_{max} - A_{min}$
 A_{max} = Depth of the whole assembly displaced in the direction of the coupling.
 A_{min} = Depth of the whole assembly displaced in the opposite direction of the coupling.
 C = Bearing width.

OPERATION ANOMALIES AND LIKELY CAUSES

TEN SYMPTOMS

- | | |
|--|--|
| <ul style="list-style-type: none"> 1 – Pump does not pump. 2 – Insufficient capacity. 3 – Insufficient pressure. 4 – Pump loses priming after start-up. 5 – Pump overloads the motor. | <ul style="list-style-type: none"> 6 – Suction mechanical seal leaks e 7 – With mechanical seal has 8 – Pump vibrates or mak 9 – Bearing failure. 10 – Pump overheating |
|--|--|

LIKELY CAUSES	SYMPTOMS (NUMBER)									
	1	2	3	4	5	6	7	8	9	10
Pump was not primed.										
Pump or suction piping not completely filled with liquid.										
Suction height is excessive.										
Minimal difference between vapor pressure and suction pressure.										
Excessive quantity of air or gas in the liquid.										
Admission of air into suction line.										
Admission of air through the mechanical seal, sleeve joints, volute case joint or plugs.										
Foot valve too small.										
Foot valve partially obstructed.										
Suction piping inlet insufficiently submerged.										
Rotation too low.										
Rotation too high.										
Wrong rotation direction.										
Total height greater than the pump was designed for.										
Total height greater than the pump was designed for.										

LIKELY CAUSES	SYMPTOMS (NUMBER)									
	1	2	3	4	5	6	7	8	9	10
Density of liquid different from that used for selection.						■				
Viscosity of liquid different from that used for selection.			■	■		■				
Operation at greatly reduced capacities.										■
Operation of pumps in parallel inadequate for this application.	■		■	■						■
Foreign particles into the impeller.	■		■			■		■		
Misalignment due to dilation of piping.						■	■	■		■
Improper foundations.								■		
Warped shaft.						■	■	■		■
Rotating and stationary parts rubbing.						■		■		■
Worn bearings.							■	■		■
Worn wear ring.				■		■				
Damaged or corroded impeller.			■	■					■	
Leakage under sleeve due to deterioration of the sealing ring or joint.							■			
Shaft sleeve worn, corroded or rotating off center.							■	■		
Mechanical seal incorrectly installed.						■	■	■		
Type of mechanical seal incorrectly selected for the operating conditions.						■	■	■		
Shaft rotating off center due to wear or misalignment of bearings.							■	■	■	■

LIKELY CAUSES	SYMPTOMS (NUMBER)									
	1	2	3	4	5	6	7	8	9	10
Unbalanced impeller, resulting in vibration.							■	■	■	■
Solid abrasives in the pumped liquid.						■		■		
Internal misalignment of the parts, preventing the stationary seat and the rotating ring of the seal from properly adjusting to each other.							■	■		
Mechanical seal operated dry.							■	■		
Mechanical seal operated dry.									■	■
Excessive grease in the bearings.									■	■
Bearings not lubricated.									■	■
Bearings assembled incorrectly (damage during assembling, wrong type of bearing, etc).									■	■
Corroded bearings due to admission of water through the retainer.									■	■
Excess, lack or use of wrong grease.								■	■	■
The clearance in the coupling is not being followed according to the instructions.								■		
The motor is operating in two phases only.	■	■	■		■			■		■
Admission of air into the sealing box.	■	■	■	■	■					
Wear of internal parts of the pump.	■	■	■	■				■		
The pump-drive assembly is misaligned.					■			■	■	■
Air pocket formation in the suction piping.	■	■	■	■				■		

RECOMMENDED SPARE PARTS

For 2 continuous years of operation, IMBIL recommends the quantities of spare parts shown in the table below, according to the number of Pumps used:

Part	Denomination	1	2	3	4	5	6 and 7	8 and 9	More than 10
	Diffuser	1	2	2	3	3	4	4	40%
	Shaft	1	1	2	2	2	2	3	40%
	Impeller (set)	1	2	2	3	3	4	4	30%
	Bearing (set)	1	2	2	3	3	4	5	50%
	Packing (8-ring set)	4	6	8	8	10	10	10	100%
	Wear Ring (Set)	1	2	2	3	3	4	4	40%
	Stage Sleeve	1	2	2	3	3	4	4	40%
	Locking Sleeve	1	2	2	3	4	4	5	40%
	Shaft Sleeve	1	2	2	3	4	4	5	40%
	Separating Sleeve	1	2	2	3	3	4	4	30%
	Joint Set	2	4	6	6	8	8	8	150%
	O'ring Set	2	4	6	6	8	8	8	150%
	Mechanical Seal* *								

**** Note: The quantity of parts in a set is always equal to the number of stages minus one. If there is a mechanical seal, follow the manufacturer's recommendation.**

ORIGINAL

WARRANTY CERTIFICATE

WARRANTY TERM

The present "Warranty Term" has as objective to guarantee to the user all equipment shipments and/or the materials produced by the manufacturer, under the following conditions:

This term is valid for 12 (twelve) months from the effective start-up date of the equipment or 18 (eighteen) months from the invoicing date to the original user, whichever happens first.

The equipments and materials are covered by this warranty in regards to the repair or substitution of parts by IMBIL factory or by the authorized IMBIL technical assistance service against materials or fabrication defects, as long as there is evidence of these defects and against invoice presentation, with the following restrictions:

- All the material / equipment made by IMBIL or substituted part removed against warranty will become property of the manufacturer.
- Any repair, modification or exchanges against warranty will not prorogate the original equipment or substituted part warranty term.
- The manufacturer cannot be held responsible for losses caused by the equipment stop (Loss or Damage to Property).

The warranty does not cover:

- Transportation of the defective materials from the facility where they are installed to the manufacturer plant / technical assistance service and the later return to the original costumer facilities.
- Travel and hotel expenses from the manufacturer technician, which will be charged according to the current pricing at the time of the repair service, when this it is performed at the installation site.

This warranty loses effect if the problem happens due to the following cases:

- Operational conditions that differ from the indicated by the manufacturer.
- Normal wear caused by the use or by erosion, abrasion or corrosion.
- Incorrect use, lack of knowledge from the operator, improper use, inadequate transportation, movement or stocking, assembly or operation other than the recommended by the technical manual provided by the manufacturer.

The equipments, due to constant improvements, are subject to changes without previous notice. The warranty is effective only if this slip is sent to the manufacturer.

COSTUMER WARRANTY CONTROL

Name: _____ Serial No. _____ Invoice _____ Date ____/____/____

Address: _____

ZIP Code: _____ City: _____ State: _____ Country: _____



Pumping Solutions

Reseller – Stamp and Signature

TOLL FREE NUMBER – COSTUMER SERVICE CENTER (BRAZIL): 0800 14 8500

MANUFACTURER WARRANTY CONTROL

Serial No. _____ Invoice _____ Date ____/____/____

Name: _____

Address: _____ City _____ State: _____ Country: _____

Zip code _____



Owner Signature

Reseller – Stamp and Signature

Please fill out this form, detach it and send it to the manufacturer.

CUSTOMER SATISFACTION SURVEY

Dear Customer,

The biggest concern of IMBIL Group is to offer the best Customer Service, Product, Associated Services and Technical Support. For us, it is very important to know your opinion about the IMBIL's Quality. In knowing so IMBIL Group will be able to continually improve its quality. You can contribute by filling out this Customer Satisfaction Survey.

IMBIL GROUP thanks for your help.

Customer: _____

Address: _____

City: _____ State: _____ Zip Code: _____

Contact: _____ Date: ____ / ____ / ____

Department: _____ Function: _____

Phone: (____) _____ - _____ E-mail: _____

Region: <input type="checkbox"/> North <input type="checkbox"/> Northeast <input type="checkbox"/> South <input type="checkbox"/> Southeast <input type="checkbox"/> West Central BRAZIL	<input type="checkbox"/> Africa <input type="checkbox"/> Central America <input type="checkbox"/> North America <input type="checkbox"/> South America <input type="checkbox"/> Asia <input type="checkbox"/> Europe <input type="checkbox"/> Oceania WORLDWIDE	Application:	
		<input type="checkbox"/> Sugar and Ethanol Industry	<input type="checkbox"/> Air Conditioning
		<input type="checkbox"/> Distilleries	<input type="checkbox"/> Chemical / Petrochemical / Naval
		<input type="checkbox"/> Mining / Steel Industry	<input type="checkbox"/> Food Industry / Textile
		<input type="checkbox"/> Sanitation	<input type="checkbox"/> Steam Generation / Cogeneration
		<input type="checkbox"/> Pulp and Paper	<input type="checkbox"/> Fire Fighting
<input type="checkbox"/> Irrigation	<input type="checkbox"/> Other _____		
<input type="checkbox"/> Valve			

Product purchased: (Please indicate product's description and/ or serial numt) _____

Acquisition of product: IMBIL Authorized Distributor _____ Representative _____

	Completly Satisfied	Very Satisfied	Satisfied	Dissatisfied	Completely Dissatisfied
1. CUSTOMER SERVICES QUALITY					
* Facility for contact, agility and efficiency in providing the information requested.					
2. COMMERCIAL CONDITIONS					
* Meeting your expectations related to commercial conditions.					
3. DELIVERY TIME					
* Meeting your expectations related to delivery time.					
4. TECHNICAL INFORMATION					
* Meeting your expectations related to technical data provided with the product.					
5. DELIVERY QUALITY					
* Meeting your expectations related to product shipping conditions (packaging, visual aspects).					
6. OPERATION QUALITY					
* Meeting your expectations related to product and operation conditions promised.					
7. POST SALES					
* Efficiency on services performed					

Would you have any suggestion on how to increase customer satisfaction on IMBIL's Products / Service?

Phones for Contacts

PABX Phone: +55 (19) 3843-9833 - FAX Sales: +55 (19) 3863-0714

Sales Department: +55 (19) 3843-9809 E-mail: export@imbil.com.br

Post Sales: +55 (19) 3843-9830 e-Mail: assistenciaticnica@imbil.com.br

Quality Engineering: +55 (19) 3843-9804 E-mail: igualidade@imbil.com.br

Product Engineering: +55 (19) 3843-9870 E-mail: ienge@imbil.com.br

Customer Service: +55 DDG 0800 - 148500



IMBIL – INDÚSTRIA E MANUTENÇÃO DE BOMBAS ITA LTDA.
Rua Jacob Audi, 690 - Vila Izaura - CEP 13971-045 - Itapira-SP
PABX: *(019) 3843.9833 - FAX: Depto. Vendas (019) 3863.0714
Atendimento ao Consumidor DDG 0800.148500
<http://www.imbil.com.br> E-mail: ivendas@imbil.com.br